

پہلا دن

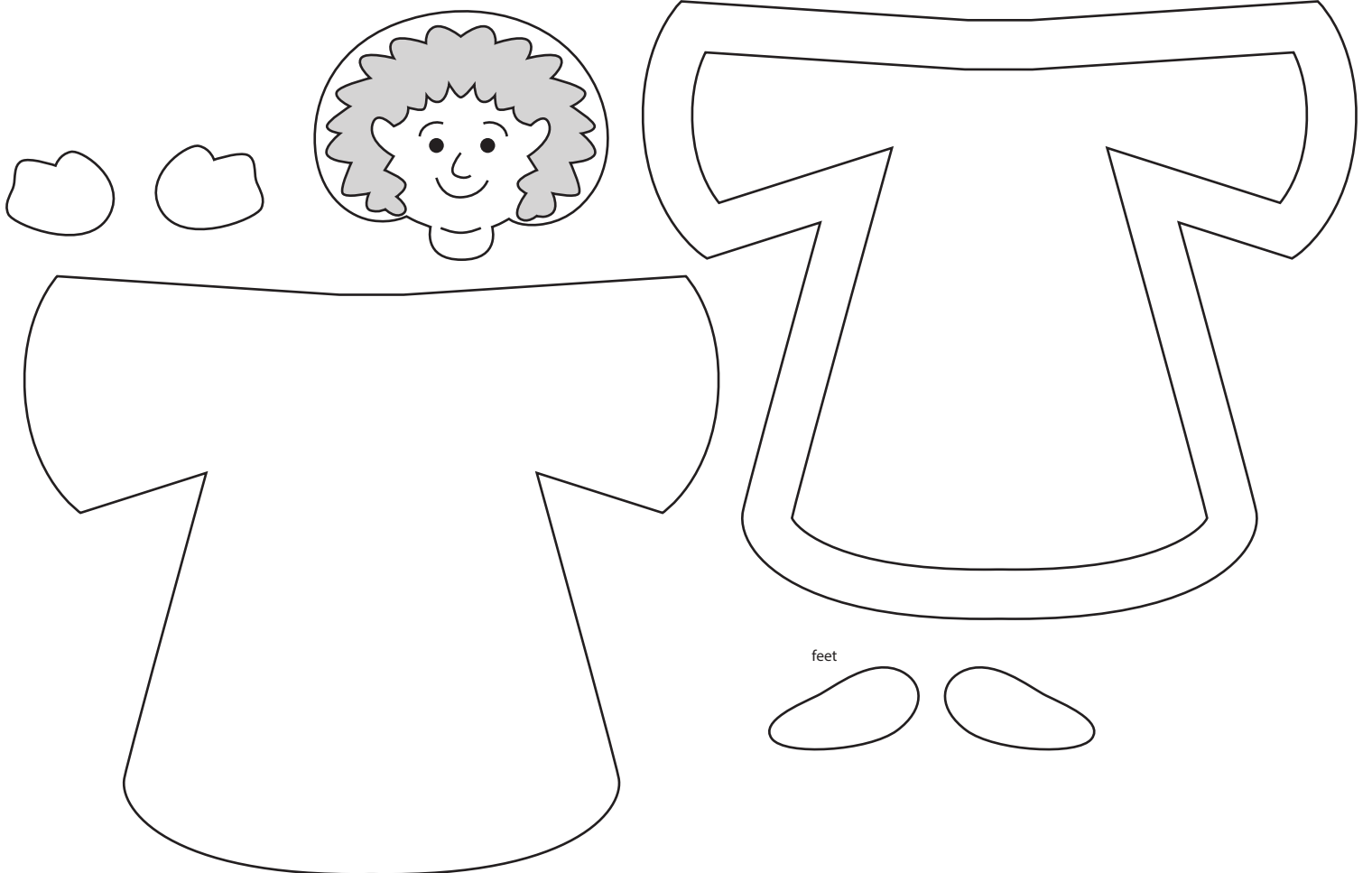
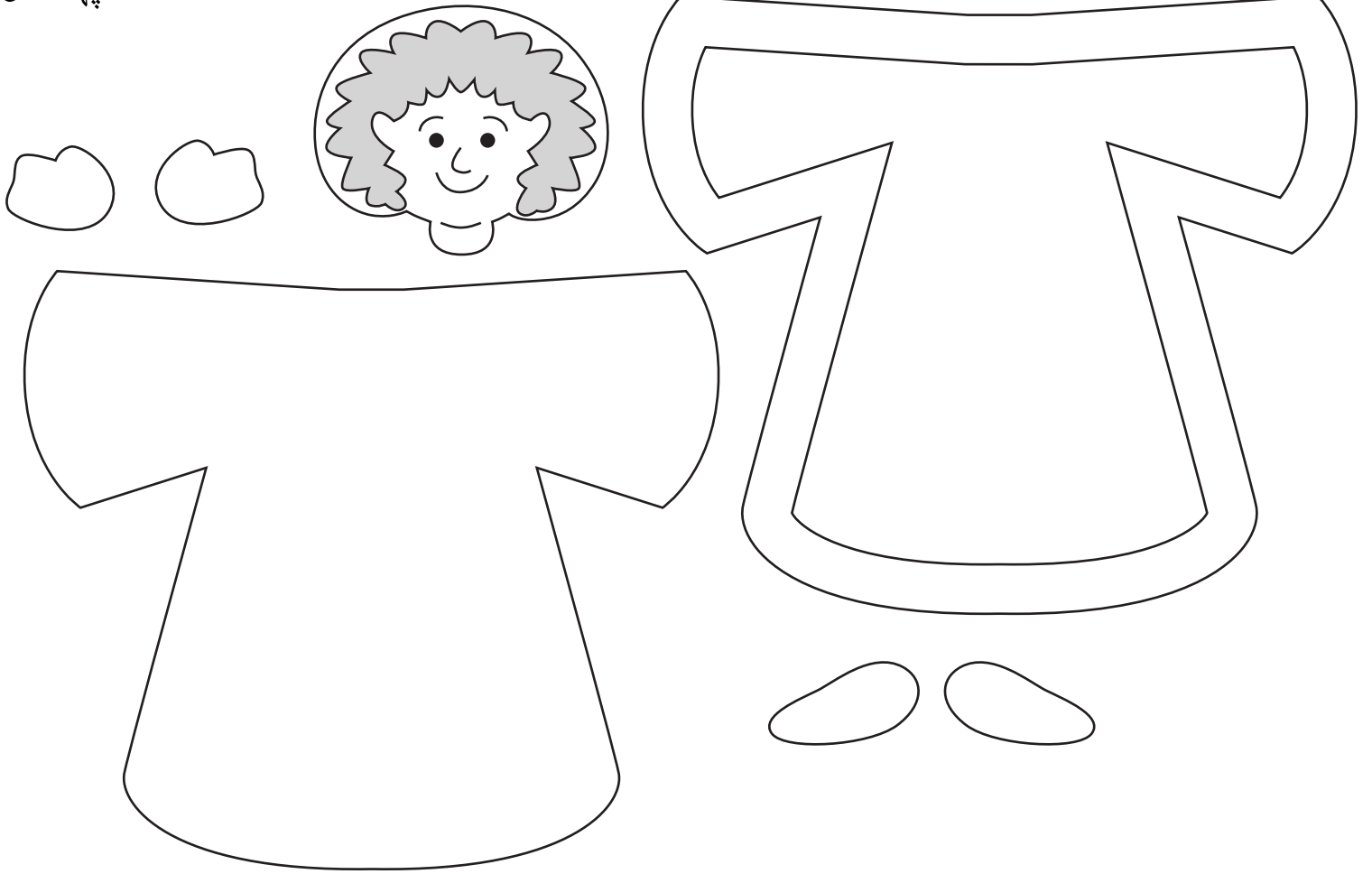

feet

سارے دل سے خُداوند پر توکلِ کراور اپنے فہم پر  
 تکیہ نہ کر۔ 6 اپنی سب راہوں میں اُس کو پہچان  
 اور وہ تیری را بُنمائی کرے گا۔ امثال 3:5-6

سارے دل سے خُداوند پر توکلِ کراور اپنے فہم پر  
 تکیہ نہ کر۔ 6 اپنی سب راہوں میں اُس کو پہچان  
 اور وہ تیری را بُنمائی کرے گا۔ امثال 3:5-6

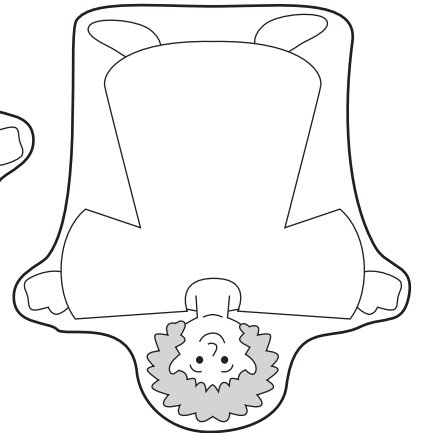
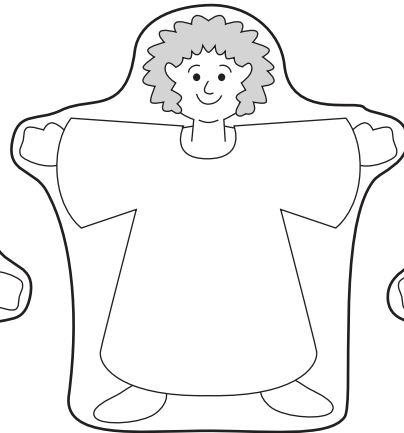
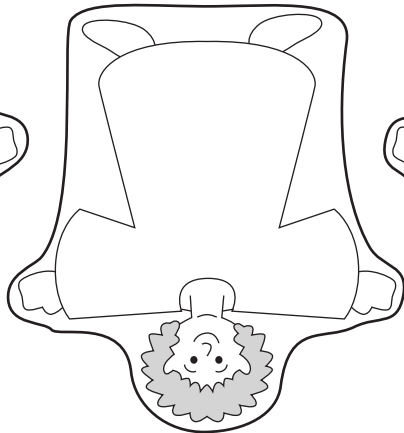
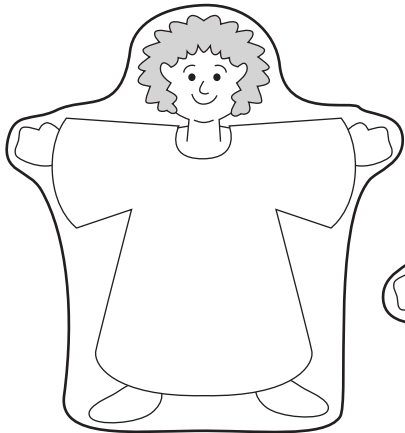
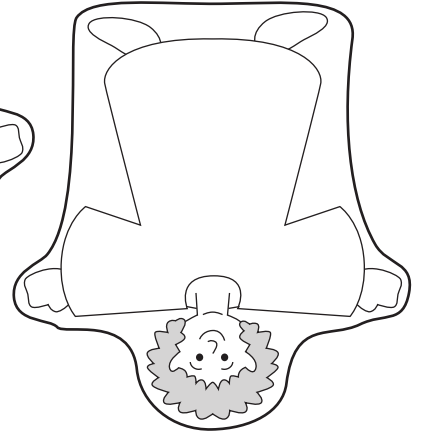
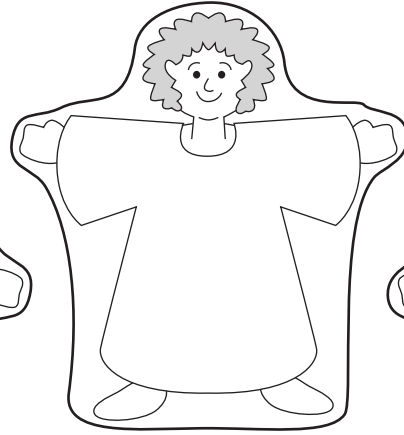
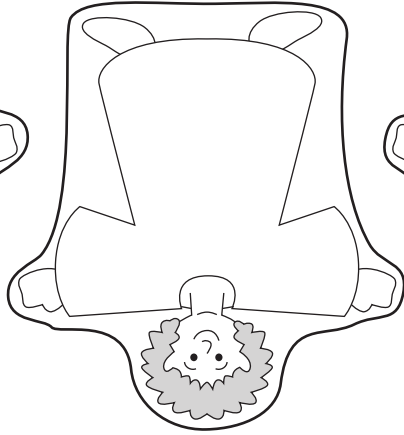
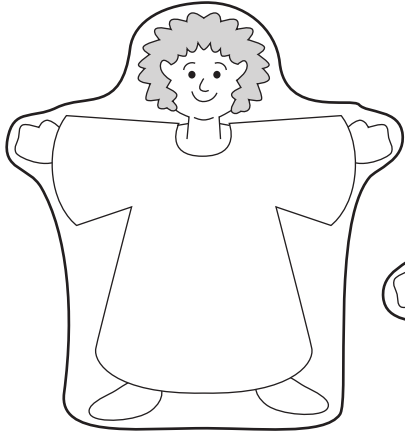
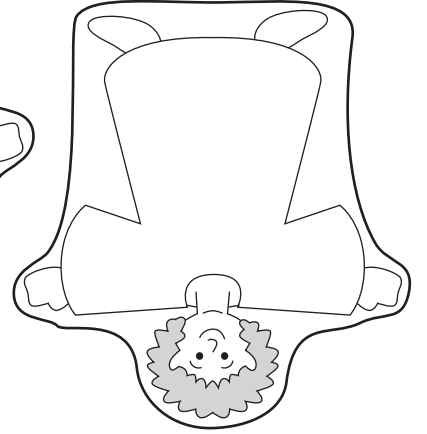
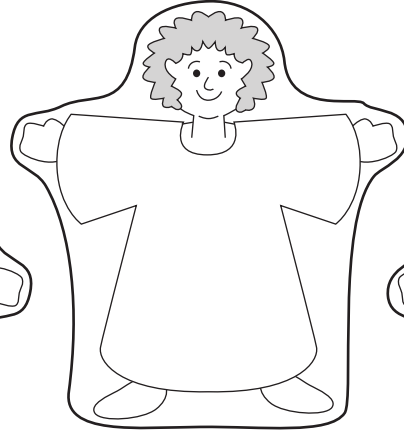
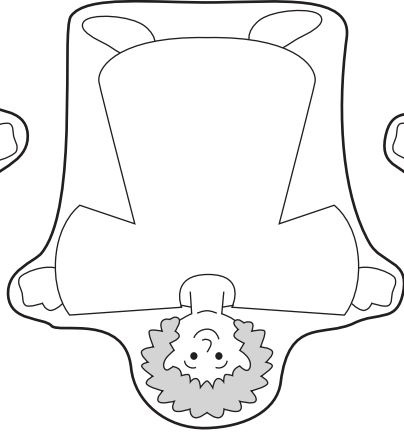
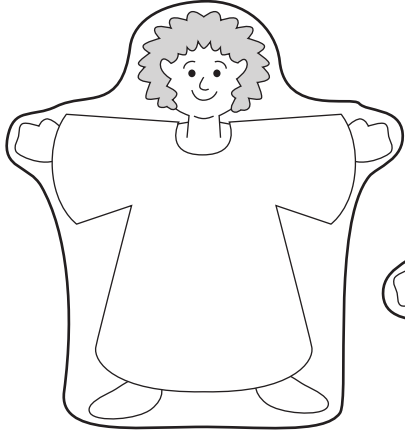
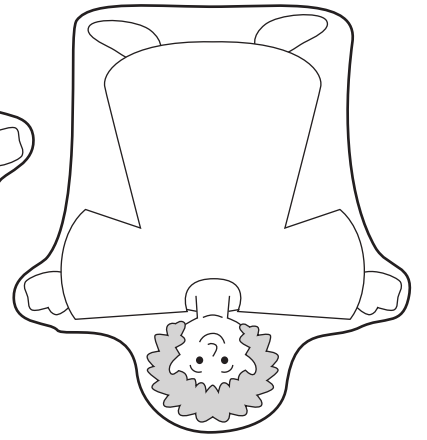
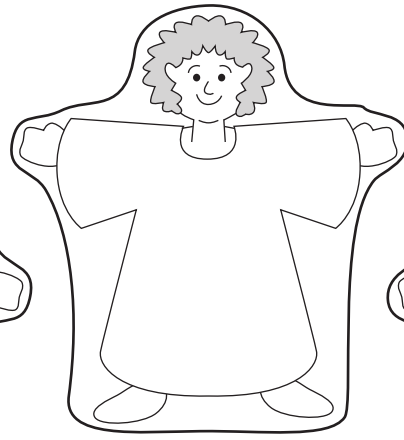
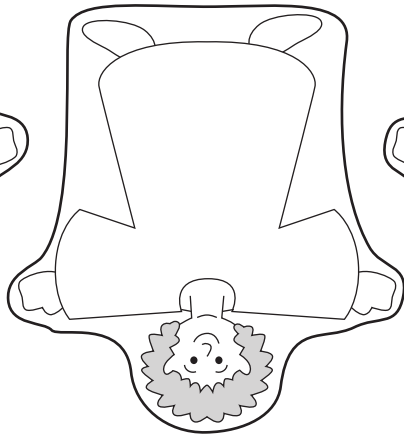
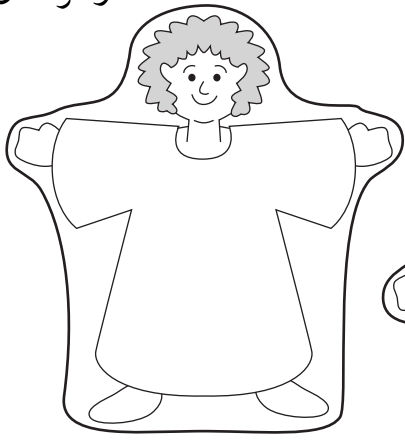



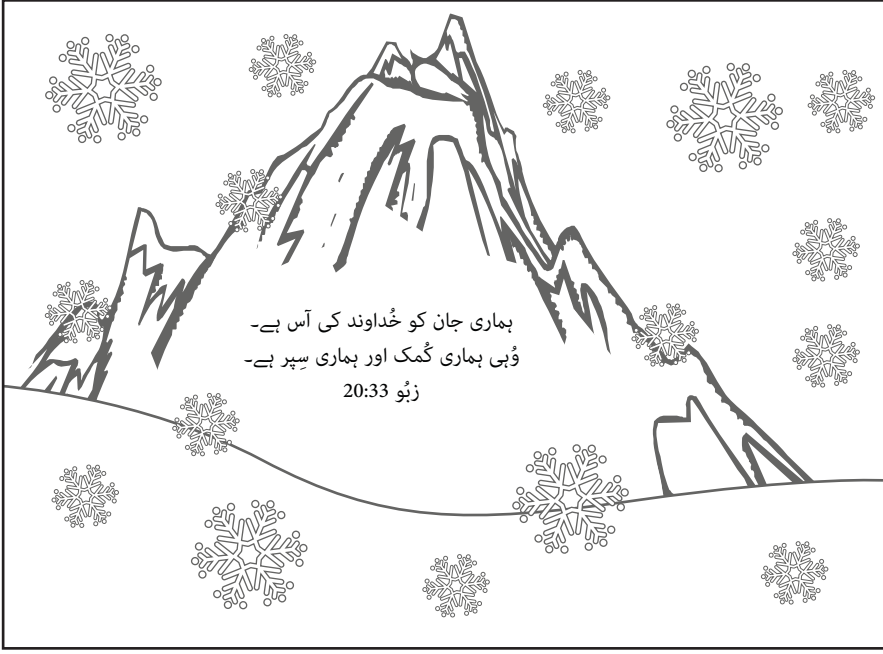

ہنزل بخیر  
کسی حد وں گے

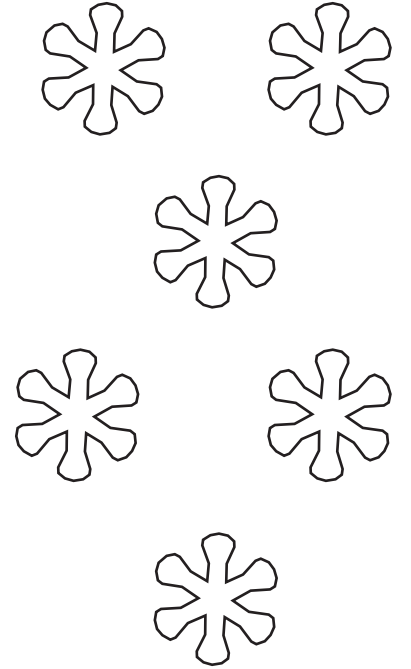
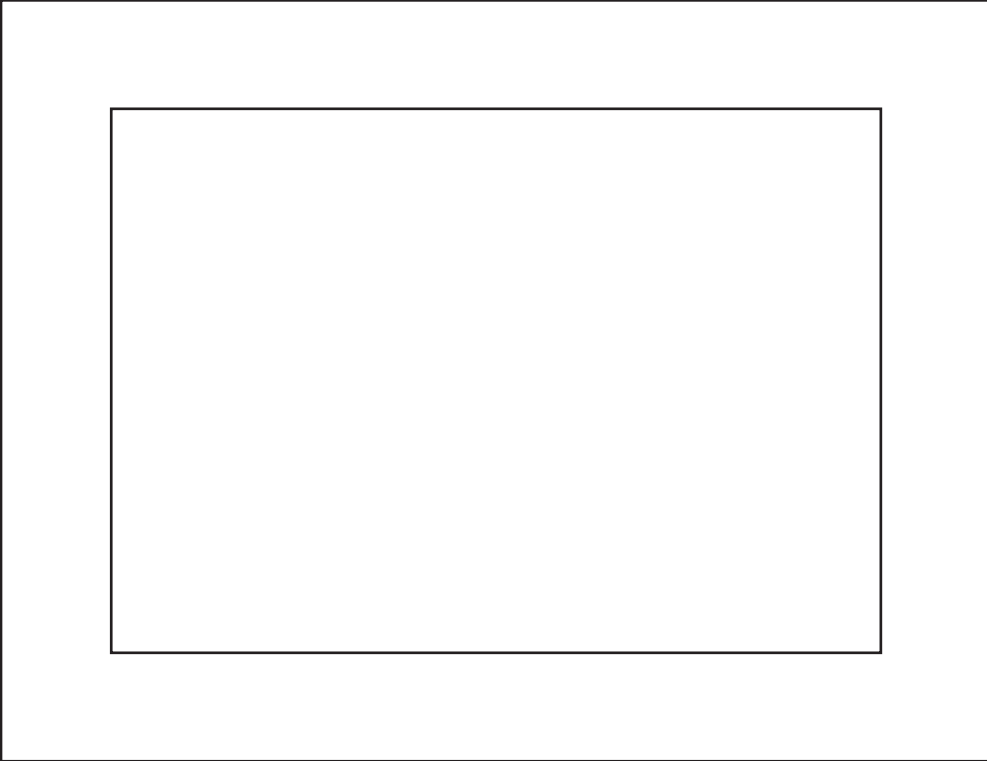

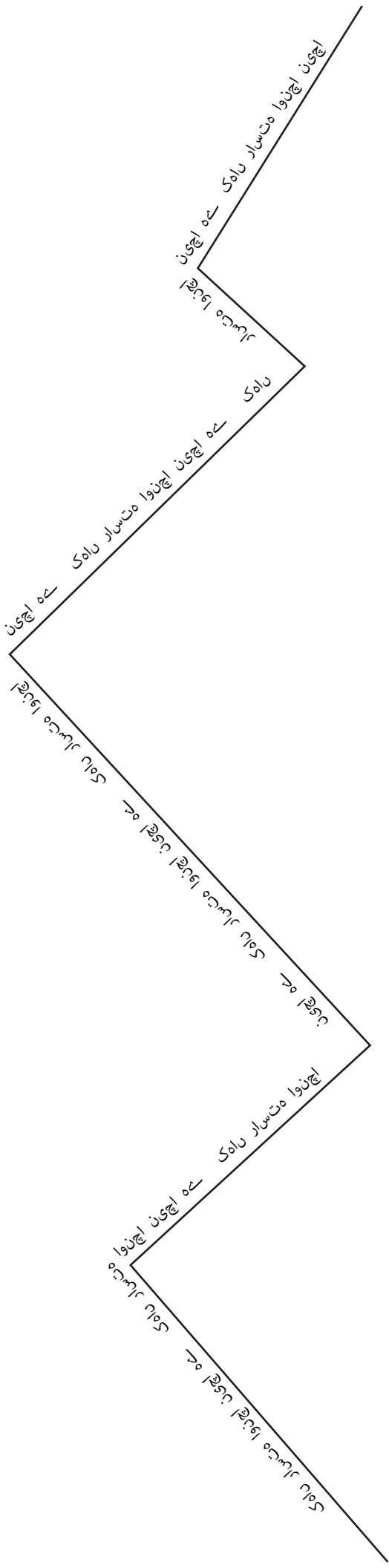

جو کوئی اپنی جان بچاتا ہے اُسے کھوئے گا اور جو  
کوئی میری خاطر اپنی جان کھوتا ہے اُسے بچائے گا۔

متی 39:10

